

VERTICASA CRIMP SET

KIT CONTENTS

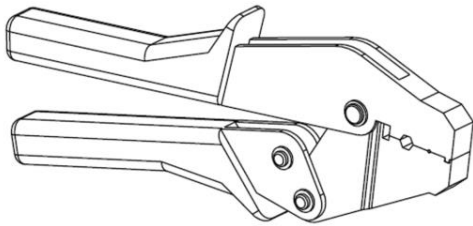

CRIMP PLIERS

CRIMP MICRO TUBE



METAL CRIMP RING 5 mm :

THE CRIMP PLIERS ARE USED TO CRIMP 5 mm TUBE.
THE CRIMP PROCESS HAS TO BE PERFORMED IN TWO STEPS LIKE
SHOWN IN THE PICTURE FOR AVOIDING THE WING CREATION.



VERTICASA CRIMP SET

1 ESFU CRIMPING PREPARATION:

THE CRIMP PLIERS ARE USED TO CRIMP A MICRO TUBE ONTO THE PULLING ROPE PLACED INSIDE THE VERTICASA DROP TUBE AND TO ONE OR TWO FIBRE MODULE(S).

THE CRIMP PLIERS ARE SUPPLIED ALREADY EQUIPPED WITH 50 MICRO TUBES.

TO EASE THE CONNECTION CUT 10 CENTIMETERS OF VERTICASA DROP TUBE WITHOUT CUTTING THE PULLING ROPE.

FEED THE FIBRE MODULE INTO THE PULLING ROPE. THE PULLING ROPE HAS A BRAID CONSTRUCTION THAT MAKES THIS OPERATION VERY SIMPLE.

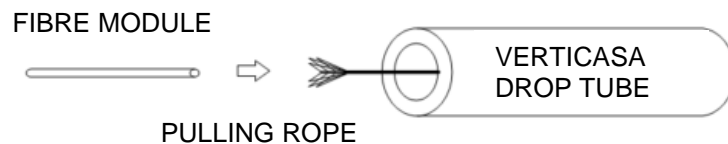

INSERT THE PULLING ROPE INSIDE THE CRIMP MICRO TUBE ACROSS ITS LONGITUDINAL OPENING.

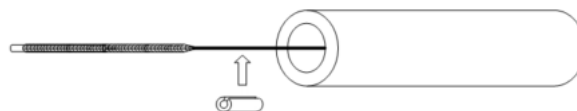

VERTICASA CRIMP SET

SLIDE THE CRIMP MICRO TUBE TO THE ZONE WHERE IT COULD ENVELOPE BOTH THE PULLING ROPE AND THE FIBRE MODULE. TO HAVE AN OPTIMAL STRENGTH IT IS REQUIRED THAT THE CRIMP MICRO TUBE BE DISTANT 30 / 40 MM FROM THE PULLING ROPE BUTT.

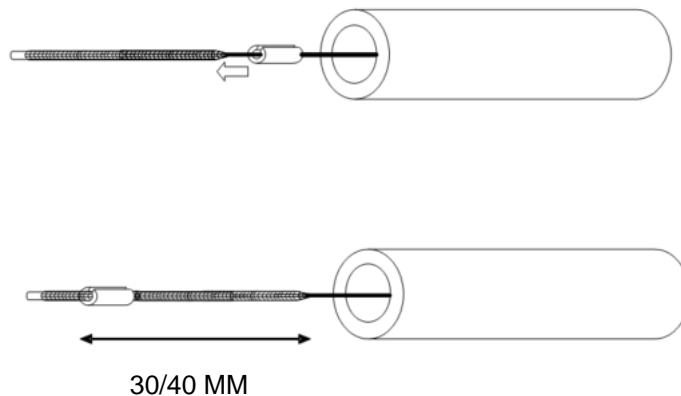

VERTICASA CRIMP SET

PRESS BY HAND THE CRIMP MICRO TUBE FOR CLOSING THE OPENING LIKE SHOWN IN THE PICTURE.

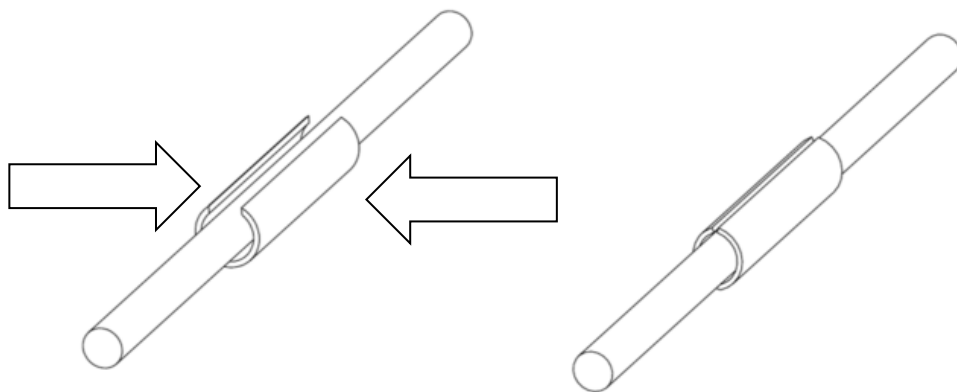

VERTICASA CRIMP SET

PUT THE CRIMP MICRO TUBE INSIDE THE SLOTTED POSITION OF THE CRIMP PLIERS: IT'S RECCOMENDED THAT THE MICRO TUBE CUT IS POSITIONATED UPWARD LIKE SHOWN IN THE PICTURE.

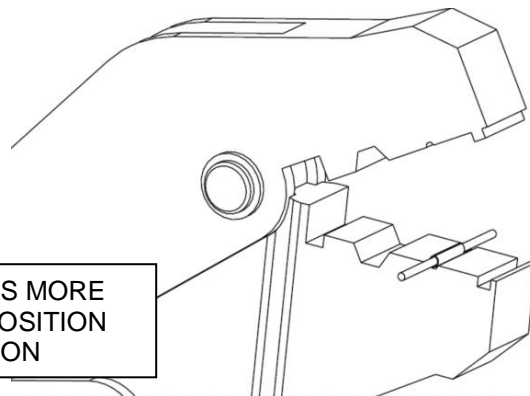

CLOSE THE CRIMP PLIERS UNTIL THE PLIERS REOPEN AUTOMATICALLY.

CHECK IF THE CRIMPED MICRO TUBE HAS BEEN DONE CORRECTLY AND APPLY A LIGHT FORCE BY HAND TO CHECK IF IT WORKS PROPERLY.

VERTICASA CRIMP SET

2 ESFU CRIMPING PREPARATION:

FEED THE FIBRE MODULES INTO THE PULLING ROPE LIKE SHOWN IN THE PICTURE. IT'S RECOMENDED NOT TO ALIGN THE TWO BUTTS OF THE FIBRE MODULES BUT MAINTAIN 2/3 MM BETWEEN THE TWO BUTTS.

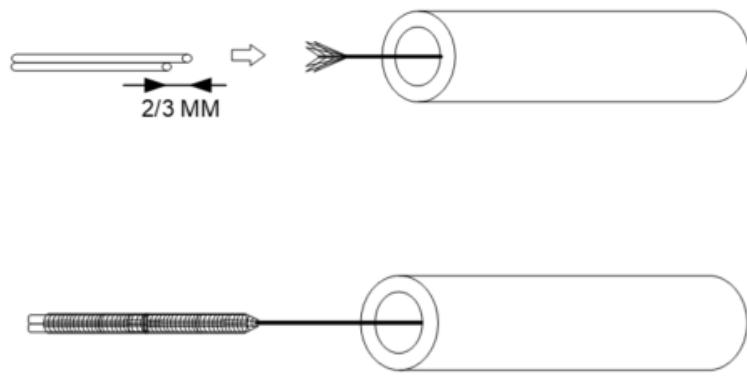

VERTICASA CRIMP SET

ENLARGE WITH THE TIP OF A SCREWDRIVER ONE SIDE OF THE CRIMP MICRO TUBE. THIS DEFORMATION WILL HELP WHEN THE CRIMP MICRO TUBE WILL BE POSITIONATED ON THE PULLING ROPE.

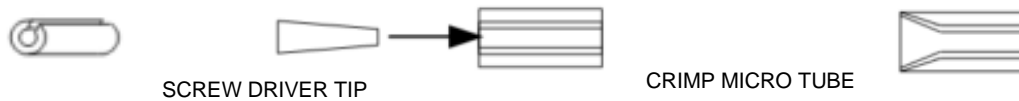

VERTICASA CRIMP SET

INSERT THE PULLING ROPE INSIDE THE CRIMP MICRO TUBE
ACROSS ITS LONGITUDINAL OPENING.

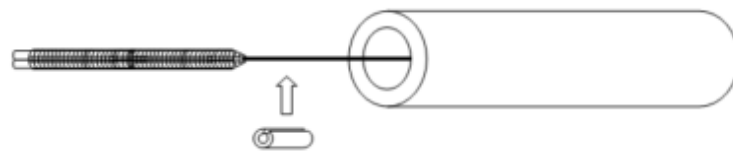

VERTICASA CRIMP SET

SLIDE THE CRIMP MICRO TUBE TO THE ZONE WHERE IT COULD ENVELOPE BOTH THE PULLING ROPE AND THE FIBRE MODULE.

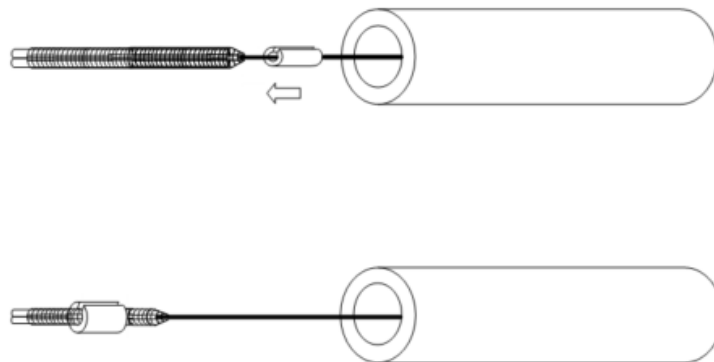

VERTICASA CRIMP SET

PUT THE CRIMP MICRO TUBE INSIDE THE SLOTTED POSITION OF THE CRIMP PLIERS: IT'S RECCOMENDED THAT THE FIBRE MODULES ARE ALIGNED VERTICALLY.

PAY ATTENTION THAT THE CRIMP MICRO TUBE IS ALIGNED WITH THE CRIMP PLIERS TO AVOID THAT THE CRIMP PLIERS COULD PINCH THE FIBRE MODULES FROM THE SIDE OF THE FIBRE MODULES.

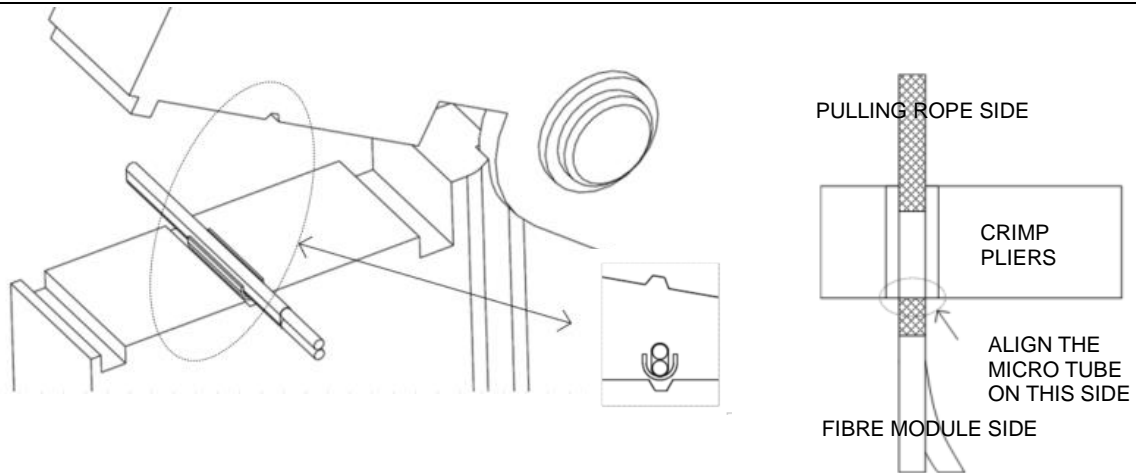

CLOSE THE CRIMP PLIERS UNTIL THE PLIERS REOPEN AUTOMATICALLY.

CHECK IF THE CRIMPED MICRO TUBE HAS BEEN DONE CORRECTLY AND APPLY A LIGHT FORCE BY HAND TO CHECK IF IT WORKS PROPERLY.